

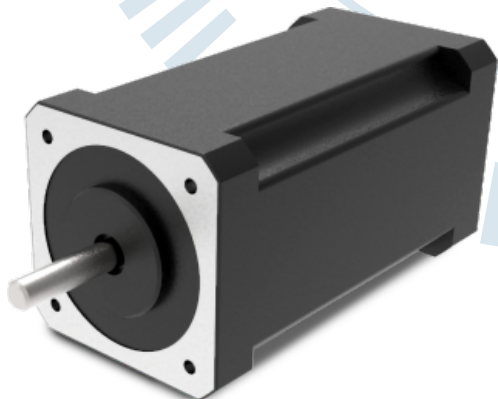

**ROTOMAJ**  
*water energy motion*

## BLDC MOTORS

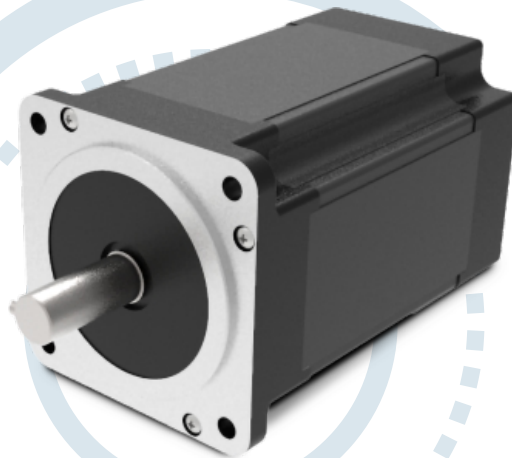

**Size: 42 to 110**

**Power: 20W to 3KW**

**Sensor or Sensor less**

**Voltage Option: 12V to 96V**



Brushless DC motor systems combine compact yet powerful brushless DC motors and high performance drivers to offer excellent energy savings and speed stability as well as a wide speed control range. With brushless DC motors you can downsize your application as the motors have slim bodies and provide high power due to permanent magnets being used in the rotor.

Brushless DC motors require less maintenance, provide long life, low EMI, and quiet operation. They produce more output power per frame size than AC or permanent magnet DC motors. Low rotor inertia improves acceleration and deceleration times while shortening operating cycles, and their linear speed/torque characteristics produce predictable speed regulation. With brushless DC motors, brush inspection is eliminated, making them ideal for limited access areas and applications where servicing is difficult or not desired. Low voltage models are ideal for battery operation portable equipment, or medical applications where shock hazards cannot be tolerated.

## Comparison of Different Variable Speed Systems

Features	Brushless DC	PMDC	AC 3-Phase
Brush wear, brush replacements	Never	Yes	Not Required
High torque at speeds above and below rated	Yes	Yes	No
Noise Level	Lowest	Higher	Higher
Performance	Best	Good	Limited
Speed Range	Widest	Widest	Limited
Control required	Yes	Yes	Yes

- ▲ SILENT OPERATION
- ▲ WIDE RANGE OF SPEED CONTROL
- ▲ SMOOTH TORQUE OUTPUT
- ▲ COMPACT SIZE- HIGH POWER
- ▲ ENERGY EFFICIENT
- ▲ LOW VIBRATION
- ▲ LOW TEMPERATURE
- ▲ LONG LIFE

# STANDARD RANGE

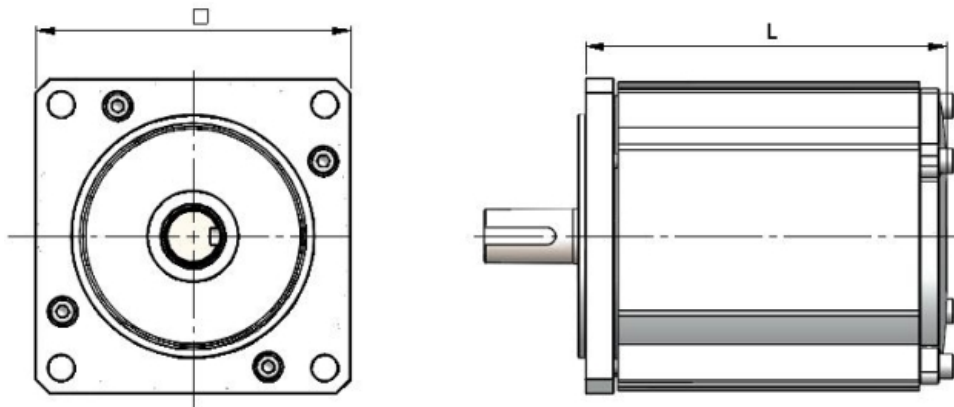

Model	Power	Speed	Current @VDC						Torque	Size	Total Length "L"
	Watt	RPM	12	24	36	48	72	96	Nm	mm	mm
R42BL20	20	3000	2.1	1.0	0.7	0.5	-	-	0.06	42	41
R42BL30	30	3000	3.1	1.6	1.0	0.8	-	-	0.10	42	61
R42BL40	40	3000	4.2	2.1	1.4	1.0	-	-	0.13	42	81
R42BL50	50	3000	5.2	2.6	1.7	1.3	-	-	0.16	42	81
R57BL30	30	3000	3.1	1.6	1.0	0.8	-	-	0.10	57	60
R57BL50	50	3000	5.2	2.6	1.7	1.3	-	-	0.16	57	80
R57BL75	75	3000	7.8	3.9	2.6	2.0	-	-	0.24	57	80
R57BL150	150	3000	15.6	7.8	5.2	3.9	-	-	0.48	57	115
R60BL30	30	3000	3.1	1.6	1.0	0.8	-	-	0.10	60	60
R60BL50	50	3000	5.2	2.6	1.7	1.3	-	-	0.16	60	80
R60BL75	75	3000	7.8	3.9	2.6	2.0	-	-	0.24	60	80
R60BL100	100	3000	10.4	5.2	3.5	2.6	-	-	0.32	60	100
R60BL150	150	3000	15.6	7.8	5.2	3.9	-	-	0.48	60	115
R86BL90	90	3000	9.4	4.7	3.1	2.3	-	-	0.86	86	60
R86BL150	150	3000	15.6	7.8	5.2	3.9	-	-	0.48	86	70
R86BL200	200	3000	20.8	10.4	6.9	5.2	-	-	0.64	86	70
R86BL300	300	3000	31.3	15.6	10.4	7.8	-	-	0.96	86	80
R86BL450	450	3000	46.9	23.4	15.6	11.7	-	-	1.43	86	90
R86BL750	750	3000	-	39.1	26.0	19.5	-	-	2.39	86	130
R110BL600	600	3000	-	31.3	20.8	15.6	-	-	1.91	110	93
R110BL1000	1000	3000	-	52.1	34.7	26.0	-	-	3.18	110	123
R110BL1500	1500	3000	-	78.1	52.1	39.1	-	-	4.78	110	153
R110BL2000	2000	3000	-	104.2	69.4	52.1	-	-	6.37	110	183
R130BL2100	2100	2000	-	102.7	68.6	51.3	34.2	25.7	10.00	130	237.5
R130BL2400	2400	3000	-	118.6	78.4	59.3	39.5	29.6	7.70	130	201.5
R130BL3100	3100	3000	-	154.0	101.3	77.0	51.3	38.5	10.00	130	247.5

# AVAILABLE SIZES

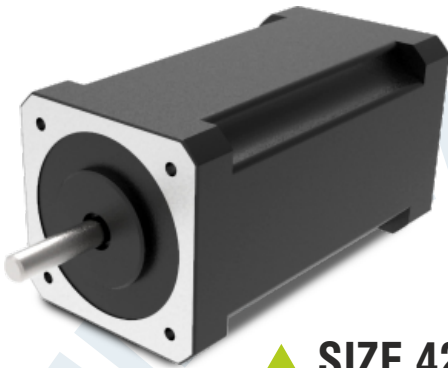

▲ SIZE 42



▲ SIZE 57/60

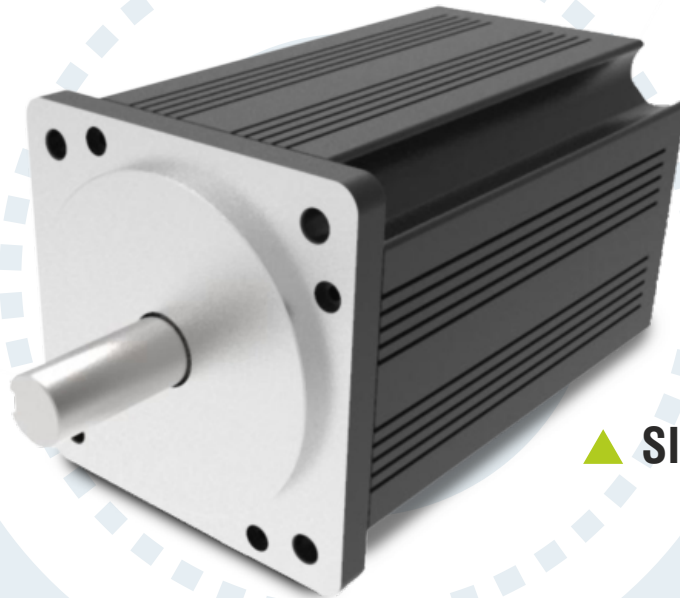

▲ SIZE 130

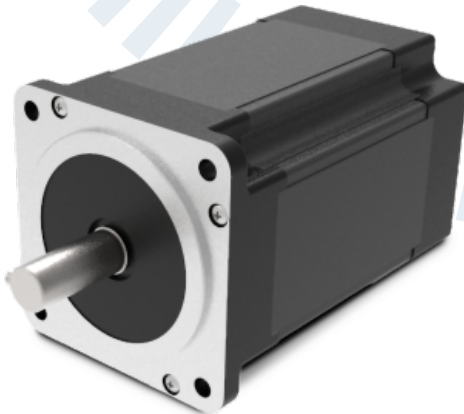

▲ SIZE 86



▲ SIZE 110



Color, Appearance may changes based on power rating & model.

Model	V	Amp	Watts	Length (mm)	Width (mm)	Height (mm)
RBZM1210F	10~15	10	150	96	61	28
RBZM4805F	24~48	5	180	96	61	28
RBZM4810F	24~48	10	300	112	76	33
RBZM12Z30S	10~15	30	360	180	118	68
RBZM4815F	24~48	15	500	150	98	53
RBZM24Z30S	18~32	30	720	180	118	68
RBZM4830F	36~60	30	1440	180	118	68
RBZM24Z50S	18~36	50	1200	205	165	78
RBZM48Z50S	24~72	50	2400	205	165	78
RBZM72Z80S	24~72	80	5760	175	98	59
RBZM72Z150S	24~85	150	3000	196	131	80

## MAIN FEATURES:

- ▲ Square wave control, constant current mode, infinite speed regulation;
- ▲ High torque, high speed output, the maximum speed can reach 10000rpm / min;
- ▲ There are EN (enabling), DIR (direction), X1 (brake) signal control end;
- ▲ Speed measuring pulse FG (gate output);
- ▲ Can output the alarm signal for users to detect;
- ▲ With over pressure, motor blocking rotation and other protection functions.

# TERMINAL INTERFACE DESCRIPTION



Function	Mark	Description
Pilot Lamp	Power	Green power supply indicator light, power-on light indicates that the power supply is normal.
	Alarm	Red status indicator light (1) The red light is out when normal; (2) The red light is always on when the EN does not receive the GND; (3) Red light flash 2 for 1s when undervoltage (power voltage <10V); (4) When overvoltage (power voltage > 16V), red light flash 3 for 1s; (5) When the motor is blocked, the red light flashes for 5 times for 1s; <i>Note: When the drive is under voltage or over voltage protection, the driver automatically removes the protection after adjusting the voltage to the normal operating voltage.</i>
Control the signal end	+5V1	Positive control signal power supply (built-in power output)
	VS P	Change the VSP end voltage to achieve 0 to 100% speed adjustment, range 0 to 5 V. (When the drive is protected, the VSP terminal voltage is 0)
	X1	Motor brake control, X1 is not connected or connected to + 5V motor normal rotation, X1 is connected to GND, motor brake stop, red light often out
	FG	The motor speed pulse output can be converted by measuring the signal frequency to the actual speed of the motor
	DIR	Motor forward and reverse control, DIR is connected to GND 1, motor reverse; DIR is not connected or connected to + 5V, motor forward rotation
	EN	1. Motor enabling control, EN connected to GND 1, motor turning (online state); EN not connected or connected to + 5V, motor not turned (offline state), red light is always on. 2. Remove the protection. When the drive is protected, the protection is removed by connecting the EN again after troubleshooting.
	ALM	Alarm output, ALM output high level 5V in normal operation, ALM when there is a fault, output low level 0V
	GND1	Control the signal power supply ground
Hall signal end	+5V 2	Motor Hall power supply is positive.
	H U	The Hall sensor signal is a U phase input.
	HV	Hall sensor signal V phase input.
	H W	The Hall sensor signal W phase input.
	GND 2	Motor Hall power supply ground.
Motor and power end	U ∙ V ∙ W	Three-phase output signal of the motor, connected to the motor winding.
	GND ∙ VH	DC D C 10V ~16V power supply power supply input.

# FUNCTION DECLARATION



<p><b>Speed-measuring signal output (FG)</b></p>	<p>The driver provides a motor speed measuring pulse signal, which is proportional to the motor speed. Speed calculation method:              Motor speed (RPM) = FN 60 F = the frequency on the FG foot using the frequency table N = motor pole logarithmic (2 N=2; 4 N=4)              For example, the user chooses 4 opposite pole motors, then:              when the output FG signal is 200Hz, the motor speed =200*60/4=3000 rpm.</p>
<p><b>Motor positive / reverse signal (DIR )</b></p>	<p>The forward and reverse version of the motor can be controlled by controlling the conversion of high and low levels of the terminal DIR.</p> <p><i>Note: In order to avoid the sudden change on the motor and mechanical equipment when the motor is running at high speed, when the DIR terminal receives the change signal, the driver first lets the motor slow down until it stops, and then the motor changes the steering and increases the speed up to the set speed.</i></p>
<p><b>Motor start / stop signal (EN)</b></p>	<p>By controlling the conversion of high and low level of terminal EN. When the EN is low level, the motor is running normally; when the EN is high level or not connected, the motor stops working, is in a free state, the red light is always on, with the start / stop end, the motor is naturally stopped naturally, and its movement law is related to the load inertia. At this point, the drive input current is 30 mA. Factory settings are EN and GND 1 short connect.</p>
<p><b>Brake brake (X1)</b></p>	<p>The stop and operation of the motor can be controlled by controlling the conversion of the terminal X1. When X1 is low level, the motor brake is stopped, and the red light is off, and the motor is allowed when X1 is high level or not connected.</p>



## OPTIONS

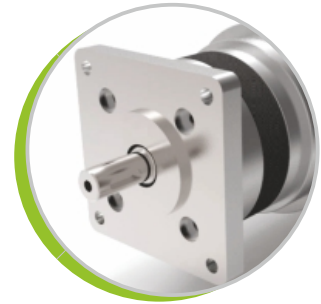
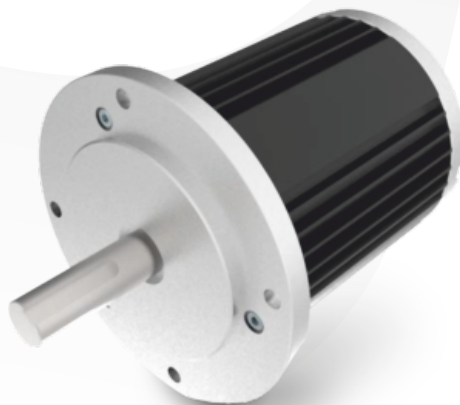
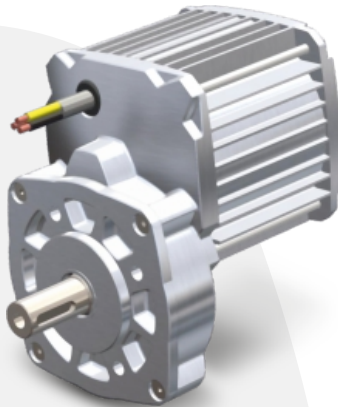

**Planetary Gearbox**



**Inline Helical Gearbox**



**Worm Gearbox**



**Temperature Sensor**



**ROTOMAG**

DC MOTORS FOR  
INDUSTRIAL APPLICATIONS

[www.rotomag.com](http://www.rotomag.com)

**ROTOMAG**  
*Water from the Sun*

SURFACE & SUBMERSIBLE  
SOLAR PUMPS

[www.rotosol.solar](http://www.rotosol.solar)

**rotomotive**  
*looks good. performs better.*

AC MOTORS AND  
GEARBOXES

[www.rotomotive.com](http://www.rotomotive.com)

 **CYCLO**

PLANETARY & CYCLODIAL  
GEARBOXES

[www.cyplagear.com](http://www.cyplagear.com)



**ROTOMAG MOTORS & CONTROLS PVT LTD**  
2102/03 & 04, GIDC, Vitthal Udhyognagar,  
Near Anand - 388121, Gujarat, India

**Phone** : +91 92746 84894 / +91 93771 73406  
**Email** : [sales@rotomag.com](mailto:sales@rotomag.com)  
**Web** : [www.rotomag.com](http://www.rotomag.com)